

LONG TERM EXPERIENCES WITH A VERSATILE PV IN ROOF SYSTEM

Andreas Haller, Helge Hartwig Dr.
Ernst Schweizer AG Metallbau, Bahnhofplatz 11, CH 8908 Hedingen
Phone: +41 44 763 63 40, Fax: +41 44 763 64 10
e-mail: andreas.haller@schweizer-metallbau.ch, helge.hartwig@schweizer-metallbau.ch

ABSTRACT: Sloped roofs are an attractive possibility for decentralized electric power generation. A versatile PV in roof system called SOLRIF (solar roof integration frame) has been developed and brought into the market in 1999. Almost any standard PV laminate framed with SOLRIF can substitute the roofing. For about 14 MW have been distributed since then. The flexibility of the concept has proved its value.

This paper presents the basic concept, cost relations and summons the experience during 6 years of application, further development and OEM derivatives with partners. Specific features are discussed and highlighted with building examples.

Keywords: Building Integration, Building Integrated PV (BIPV), Inroof System, Supporting Structure

1 WHY PV INROOF

The need to increase the use of sunlight for decentralized electric power generation is unquestioned. Concepts for the installation of PV generators range from sloped and flat-roofs to open field installations. It is obvious, that using existing roofs makes sense especially in an urban context. Therefore building integrated PV (BIPV) will have a high relevance in the future. Furthermore architecturally pleasing systems are required.

Advantages of PV roof integration are:

- Architectural and aesthetic demands satisfied.
- Roof tiles, slates etc. substituted by PV panels save roofing costs during construction or renovation.
- Particularly suitable for renovation. This will be an important topic in the near future.
- Increased CO₂ reduction potential.
- Less insurance costs, as the system is part of the building

Although sloped roofs dealing with specific housing types are only a portion of available roofs for PV they remain to be important.

This paper presents a summary of 6 years

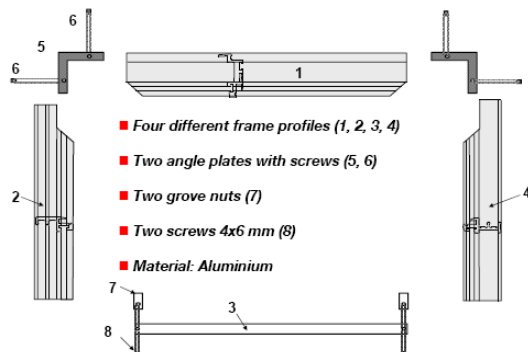

Figure 1: Elements of SOLRIF

experiences with a very versatile PV in roof system called SOLRIF (SOLAR Roof Integration Frame) and highlights concepts of realized projects.

2 CONCEPT OF SOLRIF

2.1 Description

SOLRIF is based on an economically and ecologically optimised, flexible aluminium frame, adjustable to almost every unframed PV module (laminate). With this frame any standard PV laminate can substitute sloped roofing.

The frame consists of four different aluminium profiles (fig. 1). The profiles interlock sideways (fig. 2) and overlap vertically, similar to roof tiles. The laminates are glued with well proven adhesives into the circumferential groove of the frame to achieve a watertight PV roof tile. The PV roof tiles are mounted with clamps directly onto the wooden battens above the roof's deck. The intersection between the roof cladding and the PV roof tiles is made by flashing profiles and flashings.

Specific advantages of SOLRIF are:

- Improved self cleaning of the PV roof tiles due to free standing lower glass edge.
- Improved solar gains because snow slides off



Figure 2: Interlocking of SOLRIF frame to assure rain tightness similar to roof tiles.

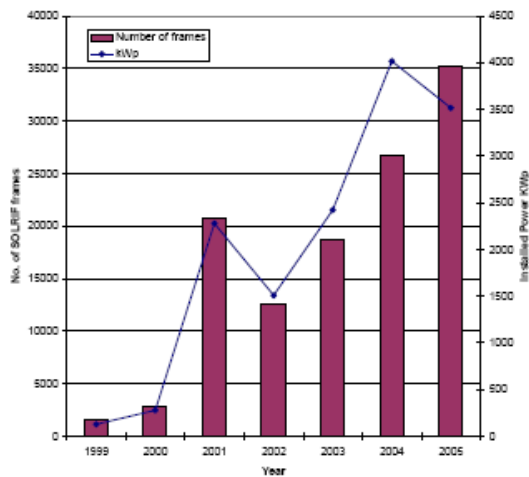

Figure 3: Number of SOLRIF frames distributed from 1999 to 2005 with the estimated power of PV installation.

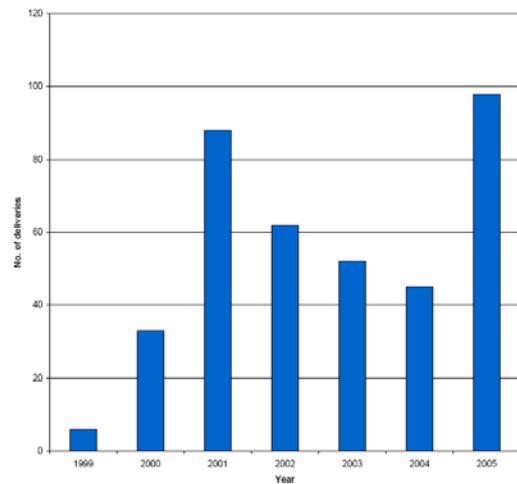

Figure 4: Number of SOLRIF deliveries from 1999 to 2005.

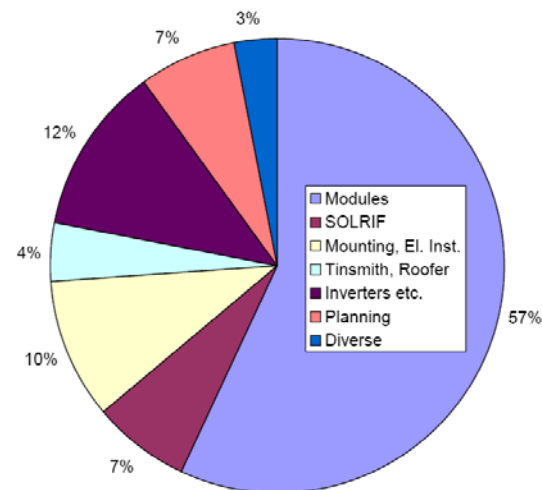

Figure 5: Average cost relation between SOLRIF and a whole PV facility.

markedly sooner than is the case with conventionally framed modules.

- Swift and economical installation method.
- Modules can be removed or changed individually during maintenance or repair.
- Frame can be powder coated with highly weather resistant lacquer to optimise the visual appearance or adapt it to the colour of the PV laminates.

3 EXPERIENCES

3.1 Module Dimensions

In the early times of SOLRIF typical PV module power was 70 to 90 Wp with a size of 0.7 m². When module power and size increased (175 Wp, 1.3 m²) due to the development of the market accompanied by raising feed in tariffs an adaptation of the frame was necessary. This led to a new variant called SOLRIF XL. With a slight modification of the frame profiles, an additional EPDM sealing profile and strengthened mounting clamps the requirements could be fulfilled while retaining the general concept.

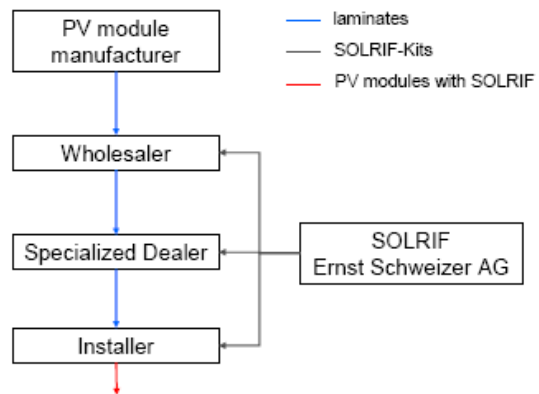

Figure 6: Direct trading of SOLRIF to different customers.

3.2 Market Development

The number of frames sold during the years (fig. 3) was strongly dependant on feed in tariffs and availability of PV laminates. Starting with few installations 1999 and 2000 the number increased rapidly with the acceptance and spreading of the concept. Feed-in tariffs have been the cause for the drop in 2002 and the new rapid incline of 2003/2004. Because of the smooth installation on a wooden substructure the use for larger PV surfaces has also been a driving force.

The estimated power kWp (fig. 3) adds to some 14 MW during the years. Besides the above-mentioned aspects the increasing power per module (1999 to 2004) and a trend to thin film technology in 2005 cause the shape of the progression.

The number of deliveries (fig. 4) is growing rapidly at the beginning: Lots of customers order their frame directly. With the establishment of partnerships (OEM-solutions) the number is diminishing. With the PV boom especially in Germany it raises again significantly in 2005.

3.3 Design Requirements

Challenging design requirements especially for high-end customers have been an important topic. The

possibility to mount PV modules horizontally and vertically within the concept has been appreciated. Backside ventilation is also improved easily with doubling of the battens on demand. Full cover roofs with flashings, dummies for shaded areas or other dimensions of the frame and roof windows while using transparent glass instead of PV modules are features, which contribute to the versatility. Where required even snow barriers can be combined with dummy fillings and SOLRIF frames.

3.4 Development of Cost Relation

With the aim to spread PV and decreasing feed in tariffs the requirement for costs of a mounting system are more stringent. Even if the frame itself is only a small portion of a PV facility (fig. 5), it has to contribute to the goal of cost reduction. This is especially difficult in times of raising prices for aluminium.

The cost for SOLRIF itself depends very much on the number of frames for an order and the size of the laminate. Typical cost ranges are shown in Table 1. Realistically the cost reduction for module installation (mounting in fig. 5) has to be taken into account for an overall cost analysis. Furthermore an important aspect of the installation for customers is the esthetical appearance, which is difficult to measure.

Table 1: Cost per Wp for SOLRIF-kits in different qualities, including mounting clamps and flashing profiles.

	SOLRIF Aluminum Blank	SOLRIF Aluminum Powder coated
Average	24 Ct/Wp	32 Ct/Wp
Minimum	15 Ct/Wp	30 Ct/Wp
Maximum	30 Ct/Wp	45 Ct/Wp

3.5 Development of Distribution Channels

The primary intention in 1999 was to ship machined frame kits to the module manufacturers for assembly in

Version: ProSOLRIF V.4.0
 Autor: H. Richter Fa. XENUM.net / G. Pimpulthar
 Kontakt: Dr. H. Hartwig: helge.hartwig@schweizer-metallbau.ch
 A. Haller: andreas.haller@schweizer-metallbau.ch

Eingaben Löschen **Köpfe zum Abpegelchem und Ablegen Erstellen**

Dach Informationen

8. Berechnungen: DIN 1055 T:4/5 2005

9. Gebäudehöhe (First): 6 m

10. Dachneigung: 35 Grad

11. Dachabmessungen

Dachlänge: 16 m (minimal: 14.74 m)
 Dachbreite: 8.5 m (7.65 m)

Ortganglänge: 5.19 m
 Modulfeildhöhe: 4.17 m
 Modulfeildlänge: 13.45 m

12. Positionierung des Modulfeldes

Abstand Modulfeildkante - Traufe (A): 0.5 m (maximal: 1.02 m)
 Abstand Ortgang links - Modulfeildkante (B): 1.25 m (2.51 m)

13. **Empfohlene Lösung bestimmen und wählen**

14. **Bestellliste und Dachplan Erstellen**

Figure 7: Dimensioning due to newest version of DIN 1055 with the software tool “ProSolrif”: Section of input data.

the regular production line and to allow them to provide the market with an in roof system as an extension to their product range. Since then two manufacturers picked up this marketing concept but failed and gave up. Our interpretation is that the PV module manufacturer is too far away from the end user and the application.

A push/pull marketing effort in 2000/2001 showed very strong response from installers (see figure 3 in 3.2). The simple framing process with minimum tooling requirements proved to be very well suited for this channel.

But most important, specialized dealers and wholesaler started to use SOLRIF as OEM system for its own branded PV in roof system.

However, with the advent of the strong market growth in Germany pushed by the EEG, the in roof concept with its inherently more complex planning process, the interest in roof applications started to decline.

As compensation to this development, SOLRIF became more attractive for larger installations as it proved to be also commercially attractive for certain situations.

The marketing concept (fig. 6) has been chosen with aim to a flexible distribution for numerous laminate types and single or multi family houses. Since the customer driven market limit the availability of laminates alternative marketing concepts are considered.

3.6 Statically Dimensioning

While the familiar Swiss market was developed easily the rapid spreading over several countries in Europe and overseas was more difficult. New and additional labels or accreditations have been required to fulfil regional requirements. For Germany statically dimensioning according to mandatory regulations, load tests according to IEC 61215 or qualification of the production environment with TÜVdotCOM seemed to be important for customers, module manufacturers and the development of the market.

Therefore a design due to current DIN 1055 has been

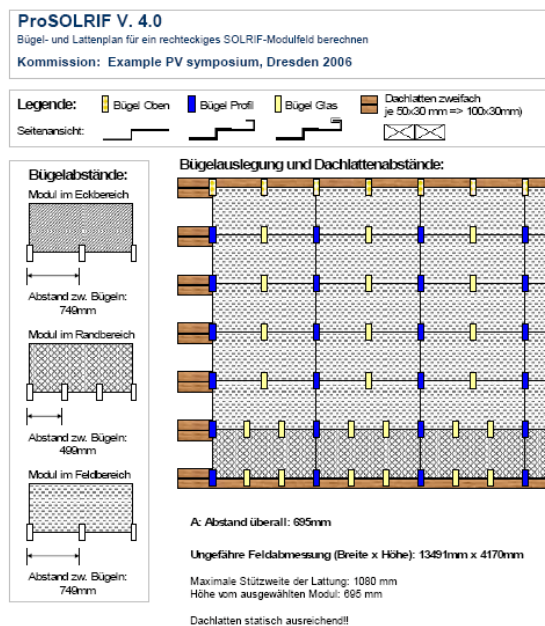

Figure 8: Output of ProSolrif: Positions of the mounting clamps.

developed. Load through wind, snow and weight is dissipated into the substructure via the clamps. The DIN 1055 distributes the roof into sections with specific wind load depending of the direction of the wind (push and pull). With a calculation tool the number and location of clamps is determined. Furthermore the sufficiency of the standard supporting battens is checked. In case of insufficient stability (PV weight plus wind push plus snow load) laths have to be added. The program calculates due to the newest version of DIN 1055 and gives a sketch of the positions of clamps (fig. 7/8).

4 EXAMPLES

4.1 Single and multi family houses

For single and multi family houses the flexibility of a roof integration system is essential. Lots of gaps or breakthroughs need to be integrated. Furthermore it is helpful if the modus of installation and achieving rain proofness is similar to conventional roof claddings. As a result the acceptance of the system is higher.

Completely covered roofs with a homogenous appearance underline the esthetical claim (fig. 9). To avoid the need for conventional roof tiles, coloured flashings and so called dummies (panes without solar-cells) are used. Dummies are also used to connect to the ridge of a hipped roof (fig. 10). Dummies are tailored and then cut on the construction site exactly following the contour of the roof. Flashings ensure the rainproofness. The integrated combination with solar thermal collectors has been used to upvalue buildings (fig. 11).

4.2 Other Buildings

School buildings are an ideal application for PV roof integration. On one hand lot's of them need to be retrofitted, on the other the impact on pupils helps to carry on the idea of future roof tops equipped with PV as a standard part of the building envelope.

Barns for storage, agricultural equipment or cattle have sloped roofs and unlike most other buildings reduced requirements for inside comfort and larger undisturbed roofs. Therefore they are very suitable for the use of solar electricity generation.

4.3 Industrial Buildings

Even if mounting with racks on large surfaces of industrial buildings with little or no slopes is mostly preferred, SOLRIF has also proved to be suitable. For example with a bitumen waterproof sheet even slope angles of around 10° are possible. The main arguments to use the in roof system have been the protection of the bitumen roof which should be exchanged every 7-8 years. With a SOLRIF cover it should last at least as long as the PV installation. Furthermore the smooth mounting, handling and ecology because of an easy to adjust wooden under structure compared to Aluminium have been reasons to use SOLRIF. At a very big mounting sight (fig. 12), the overall effort for mounting has been 4 h per kW_p including inverters, cables and flashings.

5 FURTHER DEVELOPMENTS

5.1 Tendencies for BIPV

BIPV has been subject to discussion since the beginning of PV-installation. However as mentioned in "Solar Outlook" of June 2006 "...the industry still has not developed a definition of BIPV, and is not much farther along in deploying and developing technology and products for BIPV than it was 1994". Mostly manufacturers do have solutions, but they are more adapted to their modules than to the roofing type. This is different with façade integrated PV. Large glazed facades as a current mode benefit from PV.

The superior support of BIPV by many governments (Italy, France) points out the importance of building integrated PV. Even if there are alternatives it will always play an important role with our existing and throughout decades established building stock.

5.2 SOLRIF for thin film or glass-glass laminates

Thin film technologies have a high potential for cost reduction with mass production. A limit of production costs of 0.60 €/W_p is pointed out by Antec-Solar at the OTTI-Symposium in March 2006 with production capacities above 60 MW. Many of them don't need or need much less Silicon. Therefore many manufactures expand their capabilities. Some other features of thin film laminates are important for the use with roof integration:

- Evenly black appearance
- Efficiency less dependent on temperature
- Efficiency less dependent on radiation (orientation, weather)

SOLRIF is about to be expanded for thin film or glass-glass laminates. The appearance is especially helpful for architecturally ambitious projects for roof integration.

Since thin film is less dependant of the temperature of the laminates and the efficiency has not its maximum at the normative 1000 W/m^2 a surplus of energy gain of 10 % per W_p is mentioned for average European weather conditions. This should be confirmed in further investigations. The overall costs and therefore the investment including the mounting system are lower. The calculation in €/W_p only for the mounting system might not be adequate.



Figure 9: Single family house completely covered with SOLRIF.



Figure 10: Detail of the connection between SOLRIF and the ridge of a hipped roof with dummies and flashings.



Figure 11: Combination of SOLRIF with thermal solar collectors.



Figure 12: SOLRIF roof to protect a tar-bitumen roof sheet. With a tight lower roof slope angles of 10° are possible.

6 SUMMARY

- A system based on standard modules from any manufacturer is the key to a economical viable BIPV.
- For roof integrated PV the flexibility for individual solutions, connection to other elements of a sloped roof are essential.
- The similarity to roof tiles (modularity and rain tightness) have proved advantageous and has lead to a high acceptance.
- The flexible marketing with various laminates has to be questioned in times of scarce silicon and customer driven market for framed PV modules.
- However, the interest in roof integration has proved to be stable even if the portion is varying and it remains to be a niche.
- Ecological arguments lead to wooden substructures and expand the application of a roof integration system.
- Feed in rates in some countries underline the importance of building integrated PV.
- Tendencies to thin film technology require an adaptation of the system and a different attitude referring to overall costs.
- BIPV development is part of the fluctuating PV market and therefore difficult to predict.