

Ernst Schweizer AG, Metallbau
CH-8908 Hedingen
Telefon +41 44 763 61 11
Telefax +41 44 763 61 19
info@schweizer-metallbau.ch
www.schweizer-metallbau.ch

Verkaufsbüros in:
Bern, Biel, Brugg, Chur,
Lausanne, Luzern,
Möhlin, Solothurn,
St. Gallen, Zürich



SOLRIF®XL: Description of the System

Authors: Haller Andreas / Helge Hartwig / Jochen Rasmussen
Date: April 30, 2007

Content

1	Introduction	3
1.1	In General	3
1.2	Safety	4
2	Technical Description of SOLRIF®XL	5
2.1	Field of Application	5
2.2	Framed modules	5
2.3	Suitable PV Modules - Certificates	6
2.4	Clamps for installation and fastening	6
2.5	Fastening the modules	7
3	Components for Roof Installation	8
3.1	Flashing Profiles	8
3.2	Flashings	8
3.3	SOLRIF®XL Substructure	9
3.4	Upper Seam	9
3.5	Lower Seam	9
3.6	Tools	9
4	General Planning	10
4.1	Grid Measurement	10
4.2	Generator Field	10
4.3	Grid Plan	10
5	Contact	11

1 Introduction

1.1 In General

Scope of this information

This synopsis introduces the components involved in the in-roof installation of photovoltaic (PV) modules using the SOLRIF®XL framing system. Certain aspects of SOLRIF®XL are protected by patent. SOLRIF®XL is a protected trademark. SOLRIF®XL itself is the framing fixture for the PV modules (often referred to as “SOLRIF kit”); optional components for sealing the seams are described as well. Beyond this, we will discuss general planning. Neither the installation nor the wiring of the alternating current converter, nor the power supply is a part of the SOLRIF®XL system and thus not a part of this synopsis.

Framing PV laminates with the SOLRIF®XL framing system is discussed in the document “Technical Documentation / Framing / SOLRIF”. This document is to be found at www.solrif.de under the heading “Documentations → Directions for Framing the Laminates”. Following the directions exactly will ensure a waterproof roof element.

A calculating tool for the static calculation to determine the type and the number of clamps is available on request for SOLRIF®XL contracting parties.

This synopsis should be viewed as supplemental to the installation instructions.

Rainproof

The SOLRIF®XL roof is as rainproof as a conventional tile roof. This is not to say that a roof is waterproof! Certain conditions, such as a blizzard, a torrential downpour, or a stopped eaves gutter can lead to water permeating a roof. We therefore strongly urge the use of DINplus certified roofing sheet.

Roof Boarding and Ventilation

It is essential to observe the rules of the roofing trade when boarding the roof. Strengthening the ventilation of the roof by means of a counter rafter as well as ventilating openings at the ridge and the eaves increases the durability of the substructure. In addition, the ventilation of silicon modules is favorable to energy output.

Guarantee and Liability

Our “General Terms of Business and Delivery” are valid.

For PV modules with SOLRIF®XL framing profile, delivered by the Ernst Schweizer AG company, there is a 10 year guarantee for frame components and for the waterproof sealing between frame and laminate.

In principle there is no guarantee for such PV modules not framed and delivered by the Ernst Schweizer AG company, metal construction, CH-8908 Hedingen, Switzerland, or on behalf of Ernst Schweizer AG.

Sealing the seams with flashings from Ernst Schweizer AG or with flashings of the same patent guarantees a rainproof roof in the sense mentioned above. Guaranteeing rainproof seams is the responsibility of the craftsman hired for this purpose.

Ernst Schweizer AG guarantees neither the electrical function nor the efficiency of the PV modules.

In the event of injury or damage, guarantee and liability do not apply when caused by one or more of the following:

- Improper installation
- Installation without properly employed or properly functioning safety measures and safety devices
- Disregard of the directions in the installation manual
- Disregard of general electrical rules for direct current (DC) components
- Force majeure

1.2 Safety

Dangers in working with SOLRIF®XL

SOLRIF®XL has been developed in accordance with standard specifications and with established safety regulations. Where necessary, the corresponding certificates have been procured.

Nevertheless improper handling can imperil the health or the life of the user or of a third party, or can damage or disrupt the installation or other objects.

In order to avoid dangers PV modules framed with SOLRIF®XL should only be used

- for their intended purpose
- in an absolutely safe and perfect working order
- in strict adherence to the directions in the installation manual

Damages that present safety hazards should be repaired of immediately.

Workmanlike execution

Only qualified personnel should assemble PV modules with SOLRIF. Qualified personnel are persons familiar with installing and assembling our product and starting it up, as well as persons with roofing experience. The necessity of over voltage protection or lightning protection is to be determined individually in each specific case.

Organizational measures

- The necessary personal protective gear is to be worn by all persons during installation.
- All safety devices are to be tested at regular intervals.

Informal safety measures

- In addition to those guidelines in the installation manual, the safety rules and regulations in force in individual countries should be followed at all times. Particularly the relevant installation and safety regulations (e.g. DIN VDE 0100, VDEW guideline: 2001 plus supplements, VDI 6012, BGV A1, BGV A2, BGV C22) are to be followed.
- While working atop the roof the regulations of the Roofers' Trade Association (*Berufsgenossenschaftliche Regeln Dacharbeiten*, BGR 203), the Rules for Metalwork in the Roofing Trade (*Fachregeln für Metallarbeiten im Dachdeckerhandwerk*), as well as all other rules and regulations in force in the specific country are to be followed.

- When installing modules other than prefabricated modules with fastened cables and contact-safe plugs, the wiring of the DC circuit should be executed by qualified electro-technical personnel.

Disposal

- All materials used are, when the necessity arises, to be disposed of in a proper and environmentally responsible manner.
- All components of the SOLRIF®XL system are completely recyclable.

2 Technical Description of SOLRIF®XL

2.1 Field of Application

SOLRIF®XL makes the in-roof installation of solar power generators with a maximum thickness of 5.5 mm possible, especially for modules with a glass surface greater than 0.8 m² under standard conditions as well as for smaller modules with higher standards of wind suction safeguard.

Standard conditions

- Modules with a surface $\leq 1.35 \text{ m}^2$
- Buildings with sloped roofs $\leq 8 \text{ m}$ ridge height
- Sloped roofs with an incline $\geq 25^\circ$
- Weight of snow less than 1.55 kN/m^2 ¹

Other conditions are technically possible, if necessary, with alterations to the substructure and additional anchoring. The statics can be estimated on request by Ernst Schweizer AG. There are in principle no minimal distances to ridge, skylight or eaves, but increased wind suction should be considered during calculation and planning.

Area weight

The area weight of SOLRIF®XL is, depending on the type of module, 12-15 kg per m² of the generator's surface area.

Energy Payback Time

The power demand for producing (raw materials and manufacture) a module frame is approximately 60 kWh for an 85 watt module. Assuming an output of 900 kWh/kWp there is an energy payback time of < 0.8 years. The PV module itself is not taken into account here.

2.2 Framed modules

Modules framed with SOLRIF®XL are framed fully on all four sides and provided with waterproof adhesion. The lower edge of the modules is underlaid with an aluminum profile. Dirt and grime are washed away by rain and such residues that might reduce output efficiency will not build up over time on the lower module edge.

¹ Zone I to 900 m above sea level; Zone II to 700 m above sea level; Zone III to 600 m above sea level; Zone IV to 400 m above sea level

The laminates can be set into frames by a fitter, by a SOLRIF®XL partner of the Ernst Schweizer AG, or on commission of the Ernst Schweizer AG.

The measurements of the framed modules are:

$$W \times H = \text{laminate width} + 42 \text{ mm} \times \text{laminate height} + 45 \text{ mm}$$

Caution: These measurements are not identical to the grid measurements
(see section 4.1)

Production and System Tolerances

Framed modules are delivered with a production tolerance of 0.5 mm. The special form of the interlocking side profiles allows each module a horizontal shift of ± 2 mm.

Transporting and storing of PV modules framed with SOLRIF®XL

PV modules framed with SOLRIF®XL should be stored on end and securely fastened before transport or storage. The modules should be stored with the open glass edge at top.

2.3 Suitable PV Modules - Certificates

In principle all thin-film modules under approximately 1.35 m² surface area are suitable, provided they are no stronger than 5.5 mm at the most and provided the sockets are at least 14 mm inside the edge of the glass. For modules that have sockets within 14 mm of the edge of the glass a special processing is necessary for the frame profiles.

Wind and snow-weight tests in accordance with IEC 61215 have been applied to a number of laminates framed with the SOLRIF system. These tests confirm the suitability and/or supplement the certification in accordance with IEC 61215.

An up-to-date list of tested modules can be viewed at www.solrif.de.

2.4 Clamps for installation and fastening

PV modules framed with SOLRIF®XL are secured to the wooden substructure by means of installation clamps. Therefore two different types of clamps are necessary:

“Frame” clamp:

Two modules at a time are secured in the interlocking area by means of a “frame” clamp. The clamp consists of two pieces joined together. This clamp is basic.

Clamp width: 16 mm

Material strength: 1.5 + 2.0 mm

Material: stainless spring steel, Type 1.4310

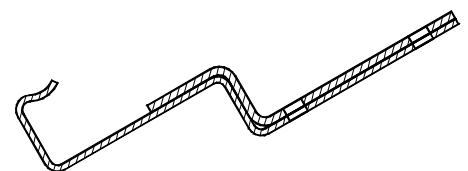

Fig. 1: “Frame” clamp

“Glass” clamp:

A module is secured additionally by means of a “glass” clamp. The clamp consists of two adhering parts. To protect the glass the front part of the clamp is covered with weatherproof coating. This clamp is supplementary measure and not always necessary.

Clamp width: 16 mm

Material thickness: 1.5 + 2.0 mm

Material: stainless spring steel, Type 1.4310

„Top“ clamp:

On top with plain flashings the modules are secured with the mounting clamp „top“. Alternatively folded flashings can be secured with mounting clamps “profile”.

Clamp width: 16 mm

Material thickness: 2.0 mm

Material: stainless spring steel, Type 1.4310

Each clamp should be fastened with two 4.5 x 30 mm SPAX-S sheet-metal A2-steel screws. The screws are not included in delivery. If several “glass” clamps are necessary, these should be set symmetrically.

Tip: Do not use screws with countersunk heads as such screws might damage the clamp.

2.5 Fastening the modules

Two interlocking frame profiles are secured from underneath by means of a “frame” clamp and secured on the top side by the next module row.

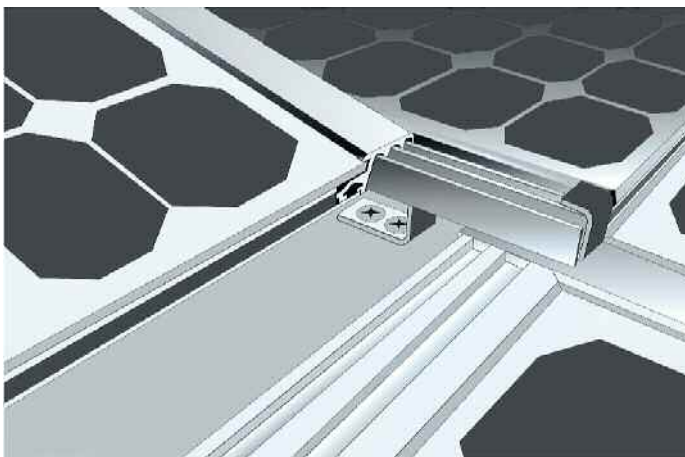

Fig. 2: Fastening the modules.

Should extra clamps be required, these clamps will touch directly upon the glass surface of the exposed underside module edge. In this case the coated “glass” clamp is to be used.

3 Components for Roof Installation

3.1 Flashing Profiles

Optional profiles, especially designed for finishing the seam on both sides of the plate and for simple sheet-metal paneling (flashing) are available for SOLRIF®XL. Additional information on the use of the flashing profiles can be found in the installation instructions.



Abb. 3: Left-side flashing profile



Abb. 4: Right-side flashing profile

Fig. 4: Flashing profile left

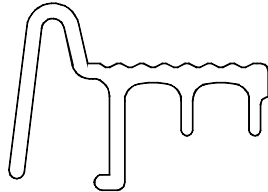
Fig. 5: Flashing profile right

3.2 Flashings

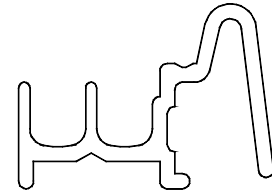
Because of the variation of module and frame measurements, the flashings have to be made individually by a sheet-metal worker or a SOLRIF®XL sales partner. They will ensure that the seam between the last profile and the roofing tiles is weatherproof.

Ernst Schweizer AG, Metallbau, distinguishes four separate flashings:

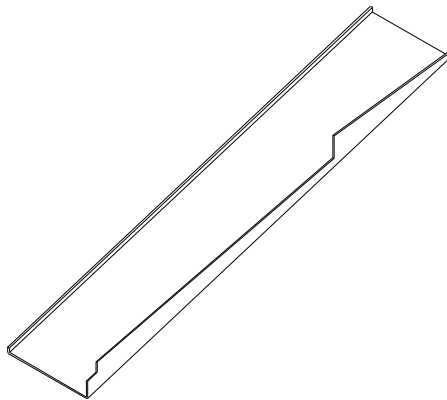

Fig. 5: Flashing top left

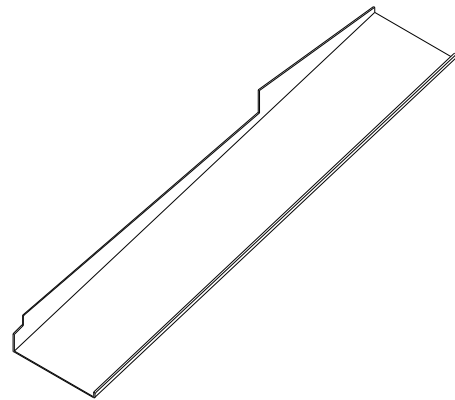

Fig. 6: Flashing top right

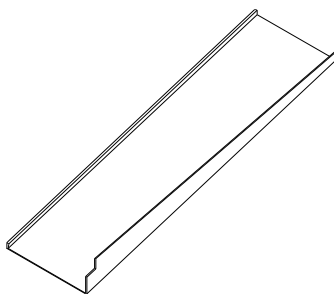

Fig. 7: Flashing left

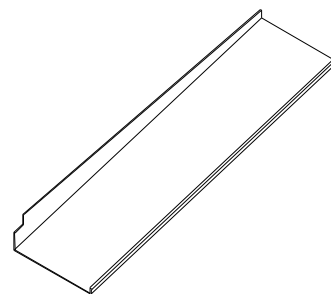

Fig. 8: Flashing right

3.3 SOLRIF®XL Substructure

The substructure of the SOLRIF®XL modules consists of SOLRIF® XL lathing. Laths measuring 30 x 100 mm – 30 x 50 mm doubled - have stood the test of time.

For eaves lathing we recommend a bevel edged board (40 x 45 or 30 mm) (cf. "Installation Instructions for SOLRIF®XL", detail drawing A).

3.4 Upper Seam

The upper seam consists of individual sheets of tin, one for each module. At the edges the tin has been specially designed to facilitate a smooth crossing to the side flashing. There are thus three different sheet forms for the upper seam. The sheets are connected at the folds by an attachable protective profile and thus made weatherproof.

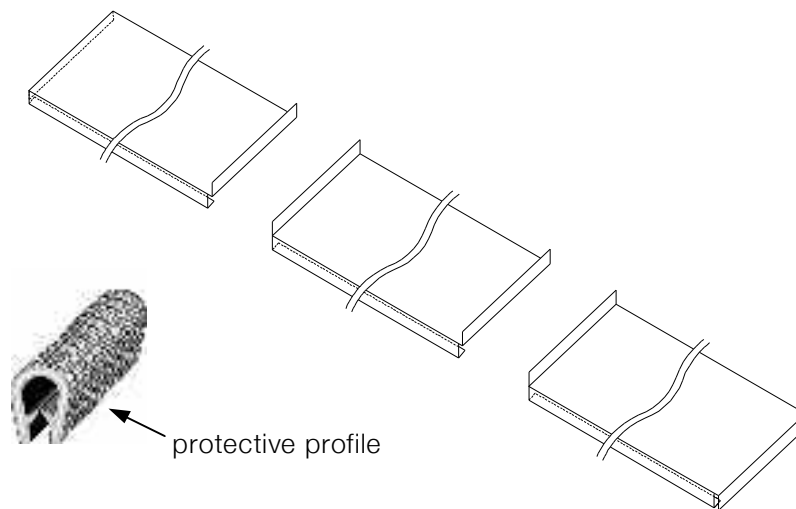

Fig. 9: Sheet forms for the upper seam, protective profile

3.5 Lower Seam

For the crossover from the lower edge of the plate to the tiles 280 mm Wakaflex band from BRAAS is suitable. Further information is to be found on the homepage of BRAAS (www.braas.de)

3.6 Tools

Few tools are needed to install SOLRIF®XL (cf. Installation Instructions).

- Preliminary to the substructure one needs:
 - *tape measure*
 - *meterstick*
 - *carpenter's pencil*
 - *wood saw*
 - *power screwdriver with bit tip holder*

- A knife is needed to cut the Wakaflex band and sealing tape.

- We recommend chalked string for marking the first row of clamps.
- In order to trim the sheet-metal, should this be found necessary, it is advisable to be equipped with metal shears and a pair of sheet-metal pliers.

4 General Planning

4.1 Grid Measurement

The exact surface area needed for the generator will be determined by the size and the number of PV modules framed with SOLRIF®XL. Under consideration of the interlocking profiles, this can be determined as:

Horizontal grid measurement: R_{hor} [mm] = laminate width [mm] + 31 mm

Vertical grid measurement: R_{ver} [mm] = laminate height [mm]

4.2 Generator Field

By multiplying the grid measurements by the corresponding number of module columns or rows one gets the approximate overall dimensions of the generator.

Generator width [mm] = R_{hor} [mm] x number of module columns

Generator height [mm] = R_{ver} [mm] x number of module rows

Under consideration of the flashing profiles one should add 15 mm to right and 15 mm to the left and then 30 mm to the height of the generator, as there is no further interlocking element for the top one.

4.3 Grid Plan

The position of the clamps on the substructure is determined by the grid plan. The grid plan is based on the calculated grid measurements.

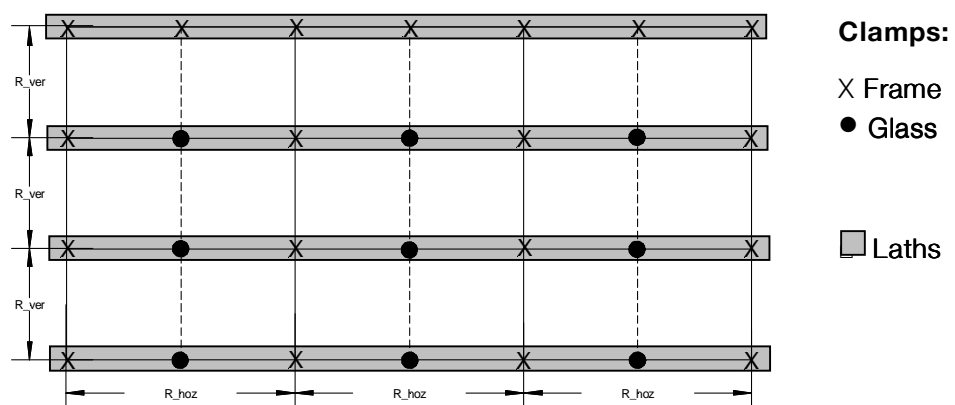

Plan 1: Standard grid plan for a generator field with 9 modules

The "glass" clamps are here added to the plan; they should be fixed as much in the middle as possible between the "frame" clamps.

Upon request you will receive an individual grid plan from your SOLRIF®XL dealer along with the delivered materials.

5 Contact

Andreas Haller
Solar Energy Department

Helge Hartwig, Dr.
PV-mounting systems

Ernst Schweizer AG, Metallbau
Bahnhofplatz 11, CH-8908 Hedingen

Phone direct +41 44 763 63 80 +41 44 763 63 40
Fax +41 44 763 64 10

andreas.haller@schweizer-metallbau.ch

helge.hartwig@schweizer-metallbau.ch

www.schweizer-metallbau.ch

www.solrif.com